

## 1 Verify kit contents

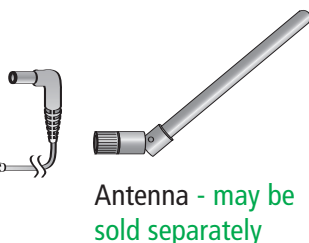

### Quick Start Guide

## ConnectPort™ WAN

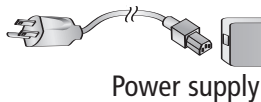
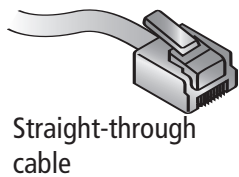
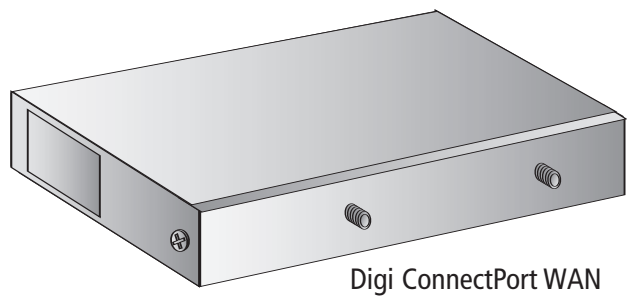

## 2 Install PC card or module

### a Remove cover

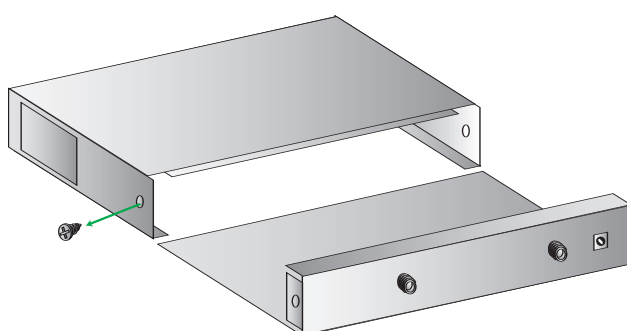

### b

Add PC card:

1. slide PC card into slot
2. attach antenna cable

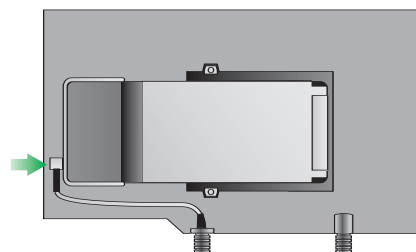
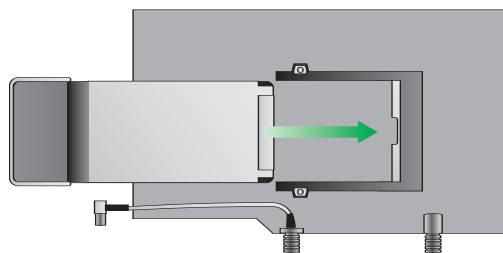

Or,

add module:

1. Snap module into place
2. attach antenna cables (MAIN to Primary external antenna and AUX to Secondary external antenna)

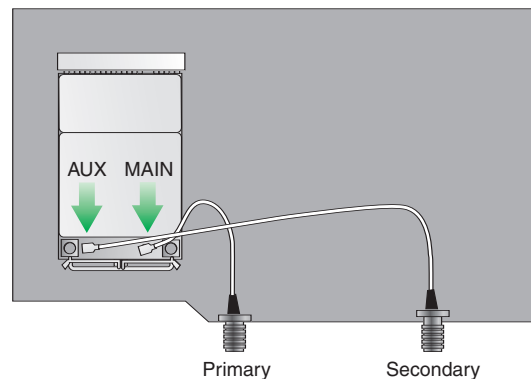

### c

Replace cover

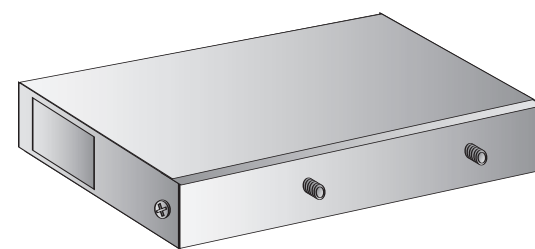

## 3 Connect hardware

**a** Install SIM card (use with GSM module only)  
Orient SIM card with metal side up and short corner to insert first. Use caution to insure card is properly seated in SIM socket

**b** Connect Ethernet

**c** Connect Power

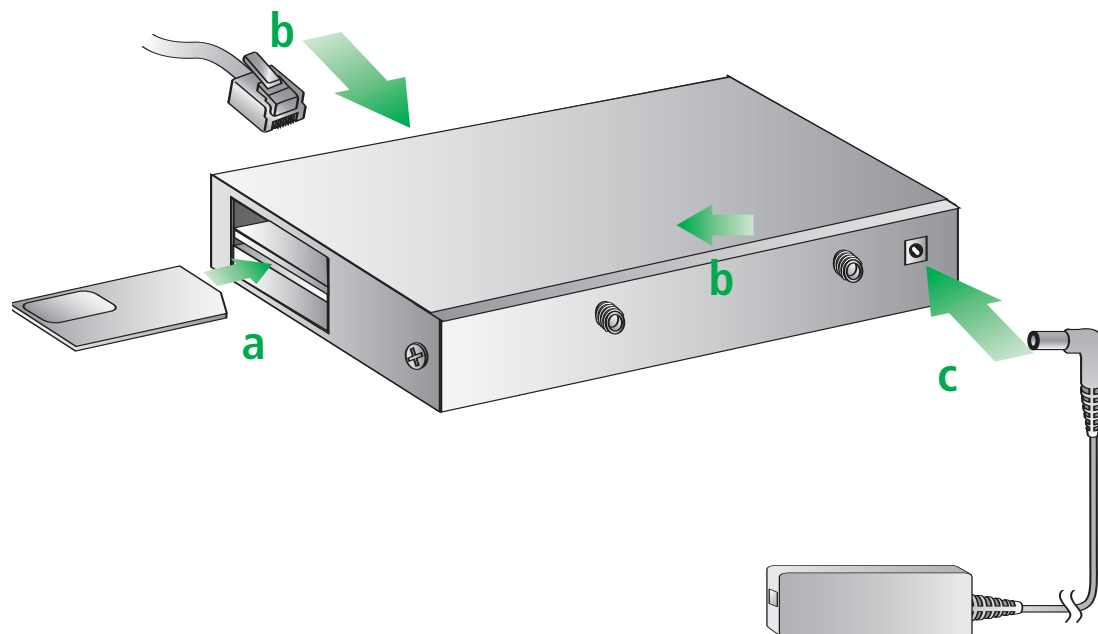

## 4 Cellular connection

**a** Open your web browser and enter the IP address 192.186.1.1 in the URL address bar

**b** From the web interface, under Configuration, click Mobile. Enter your service provider name and connection parameters and click "Apply." For CDMA carriers that support Over-the-Air provisioning, select "Click Here" to automatically provision the device, then click "Apply"

**NOTE:** The ConnectPort WAN has DHCP server enabled by default. In order to discover your Digi device, make sure your host computer is set up to obtain IP addresses automatically. Also ensure all firewall software is temporarily disabled

**c** Under Management click "connections" to verify your device has been properly provisioned.

Your connection is active if the ppp session shows (connected). For additional status on your cellular connection, go to Administration > System Information > Mobile and reference the users guide on the enclosed CD

**NOTE:** The "Link" and "Active" lights will blink when the cellular connection is active